

NEW ZEALAND ADJUSTABLE POST ANCHOR

Adjustable for post sizes up to 150mm.

FEATURES AND BENEFITS

ECONOMICAL: Inexpensive solution for fixing posts to concrete catering various post sizes from 90mm to 150mm.

EASY: No checking of post size is required.

STRONG: Hot Dipped Galvanised coating after manufacture and made from 4mm steel.

SPECIFICATIONS

STEEL	G250
THICKNESS	4mm
CORROSION RESISTANCE	HDG500 (Hot Dipped Galvanised 500g/m ²)
STEM HEIGHT	85mm, 160mm
POST SIZE	90mm -150mm

FASTENER REQUIRED

POST STIRRUP TO TIMBER POST	M10 4.6 grade galvanised hex head bolts.
POST BASE TO CONCRETE	M10 galvanised Ramset AnkaScrew

At the time of print, this product is NOT subject to any known warnings and bans found in Building Act 2004.

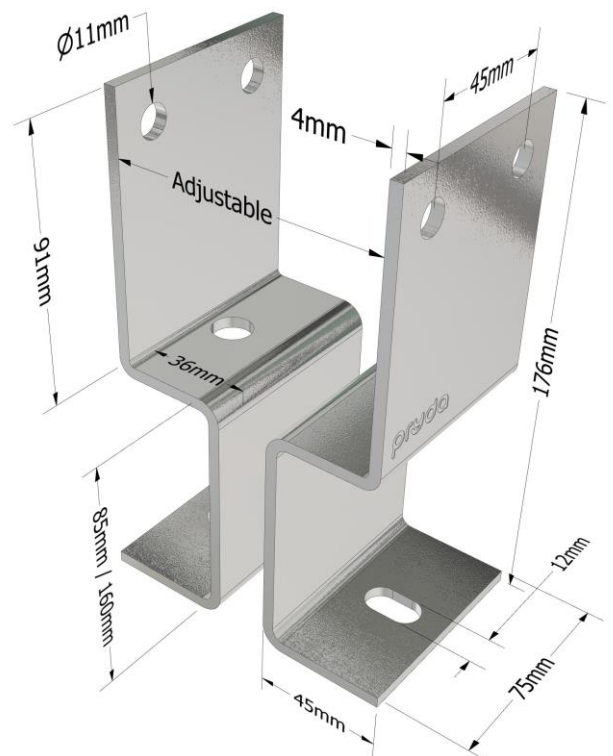

RANGE

PRODUCT CODE	MATERIAL	STEM HEIGHT (mm)	POST SIZE (mm)	BOLT HOLE SIZE	QTY
PS85/6	G250 Steel Hot Dipped Galvanised (500 g/m ²)	85	90 - 150	M10	6
PS160/6		160			

DURABILITY

Pryda Post Anchors are Hot Dipped Galvanised to standard AS/NZS 4680, as reference in Table 4.2, NZS 3604:2011. Routine inspection and clearing any debris around anchor are an integral part of the ongoing care and maintenance.

STORAGE AND HANDLING

Prior to use, the Pryda products shall be stored in a weatherproof environment and protected from moisture. Care must be taken to avoid any damage to the surface of the product protective galvanised coating and profile that may impact performance.

COMPLIES WITH THE FOLLOWING PROVISIONS OF THE NEW ZEALAND BUILDING CODE (NZBC)

Clause B1 STRUCTURE: Performance B1.3.1, B1.3.2 and B1.3.4. Loads arising from self-weight, imposed gravity loads arising from use, snow, and wind. (i.e., B1.3.3 (a), (b), (f), (g), and (h)). Only some may apply for a specific use of the component.

Clause B2 DURABILITY: Performance B2.3.1 (a) not less than 50 years and B2.3.2.

Clause F2 HAZARDOUS BUILDING MATERIALS: Performance F2.3.1.

APPLICATION AND SCOPE OF USE

Typical application for all Pryda Post Anchors is for attached open verandah or similar structures for dwellings. All other usage must be verified/designed by consulting Structural Engineer.

- The design loads tabulated above require that:
 - the timber post must bear on the Post Anchor base.
 - all post sizes to be a minimum of 90 x 90mm section UNO.
 - all anchors must be installed plumb.
 - for all bolt down anchors, support foundation must be flat, level, and supporting base plate fully.
- Select design capacity according to the standard used for determining the design loads.
- Specified capacities are for concentric vertical load transfer only. Refer to each post anchor notes for recommended capacities for eccentrically loaded conditions with selected post anchors only.
- The base concrete and fixings to the concrete must provide sufficient resistance to the uplift forces and dead + live loads. Uplift capacities stated in this document are stated for the steel and timber post ONLY, these capacities may be limited by the anchorage to the supporting foundation. This should be verified by the Project Engineer or designer prior to installation.
- Wind uplift capacities are based on the AS/NZS 1170.2 wind code.
- Post Anchors should NOT be assumed to contribute towards lateral bracing/raking stability of a structure in decks or stumps in sub-structure, unless pre-approved by a Structural Engineer.
- Post Anchors are not intended to be used for cantilever posts, balustrades, and free standing structures, i.e. carports and gazebos, unless designed and approved by a consulting structural Engineer.
- Post must be laterally restrained at top, installed centrally to anchor, and deemed to be "fit for purpose" by the project Engineer.
- It is recommended to slope the foundation away from the anchor to prevent water pooling at the base.
- Do not cover exposed base plate and stem with debris or obstacles that will facilitate collection of debris around anchor base.
- Maximum post height 3m and ultimate limit state wind speed not exceeding 50 m/s unless noted otherwise.
- Local settlement, ground water and soil reactivity will cause isolated concrete footings to 'TILT' and therefore induce bending into the post stirrup stem. Isolated footing should be restricted to stable soil, i.e. Class A and S foundation classification to AS2870.

Pryda Adjustable Post Anchor is certified when used and installed in accordance with the product datasheet connection details. Only use the product for its intended applications and the selected product material type within the specified environmental condition as outlined in NZS 3604:2011 Table 4.2. Fastener material type shall match the selected Pryda product, i.e. galvanised fasteners with galvanised products, and stainless steel fasteners with stainless steel products.

DESIGN CAPACITIES - STEEL STRENGTH ONLY

Ultimate Limit State Design capacities (Φ_{Nc} , Φ_{Nt}) for Pryda Standard Post:

PRPRODUCT CODE	AXIAL COMPRESSION Φ_{NC} (KN)	AXIAL TENSION Φ_{NT} (KN)
PS85/6	24	8
PS160/6	12	

DESIGN CAPACITIES

Limit State Design capacities (Φ_{Nj}) for Pryda Standard Post Anchors resisting wind uplift loads are as follows:

FIXINGS	POST (mm)	UPLIFT CAPACITIES FOR VARYING JOINT GROUPS (kN)		
		JD5	JD4	JD3
2 x M10 bolts or 4 x M10 x 50mm coach screws	90 - 150	5.4	7.5	7.5

Notes:

1. The design loads tabulated above require that: (a) the timber post must bear on the Post Anchor base and (b) all posts must be a minimum of 90 x 90mm section.
2. Select design capacity according to the standard used for determining the design loads.
3. Specified capacities are for concentric vertical load transfer only. As a guide, limit the axial compression load to approximately 50% of the design capacity for eccentrically loaded conditions.
4. The base concrete and fixings to the concrete must provide sufficient resistance to the uplift forces and dead + live loads when embedding into concrete.
5. Wind uplift capacities are based on the AS/NZS 1170.2 wind code and AS4055:2012
6. Post Anchors should NOT be assumed to contribute towards lateral bracing/raking stability of a structure in decks or stumps in sub-structure, unless pre-approved by an Engineer.
7. Post must be laterally restrained at top.
8. Post Anchors are not intended to be used for cantilever posts and balustrades without pre-approval from an Engineer.

INSTALLATION

It is essential that the capacity of the fasteners to foundation connection exceeds the expected uplift load. Fastener bolt selection connecting anchor to foundation to be determined by consulting project Engineer to suit design application, foundation type, and deemed "fit for purpose". Consider the use of Ramset Galvanised AnkaScrew. Refer to bolt manufacturer guidelines for recommended pre-drill hole size and depth for selected fastener. The design Engineer should ensure the structural element can support the intended design loads.

STEP 1



- Orientate anchor as required, measure and mark location of base holes using selected anchor base as stencil.
- Ensure adequate concrete edge distance set back.
- Concrete foundation support to be level horizontally.
- Seek advice from your consulting project Engineer.

STEP 2

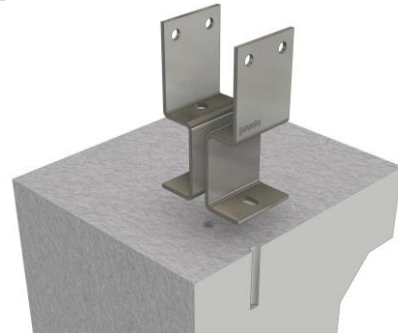

- Drill two holes at marked location to required depth for selected hold-down bolt. Refer to bolt manufacturer guidelines for recommended pre-drill hole size and depth. Suggested minimum screw embedment depth 100mm or greater (section detail shown above).

STEP 3



- Position Post Anchor and insert M10 Ramset Galvanised AnkaScrew fastener.
- Tighten fastener to pull down Post Anchor base firmly onto the concrete surface.

STEP 4



- Sealing the end grain of post before installing into anchor may be required (seek advice from project Engineer).
- Place timber post centrally into Post Anchor stirrup for direct bearing on stirrup base.
- Ensure both Post Anchor and post are vertically plumb.

STEP 5



- Drill through post using saddle holes. Ensure drill through holes are horizontally level and perpendicular to saddle.
- For coach screws, drill pilot holes to the length of selected screws.

STEP 6

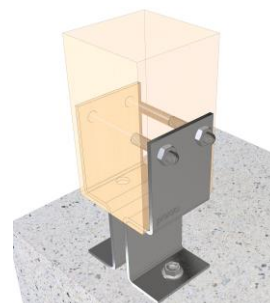

- Insert bolt through saddle and passing through timber post. A minimum of 2 x thread pitch should extend beyond the outward surface of the nut.
- Install nut and securely fasten.

INSTALLATION TIPS

FOUNDATION SLOPE

- It is recommended to slope foundations away from the base of the Post Anchor in all directions.
- Avoid water pooling and buildup of debris around anchor base.
- Not suitable for foundation that is at the same level as natural ground unless deemed “fit for purpose” and approved by consulting design Engineer.
- Routinely clear away debris or any obstructions at anchor base on a regular basis.
- Tiling or paving around anchor is not recommended as this may result in a recess space around anchor that may facilitate water pooling and debris buildup.

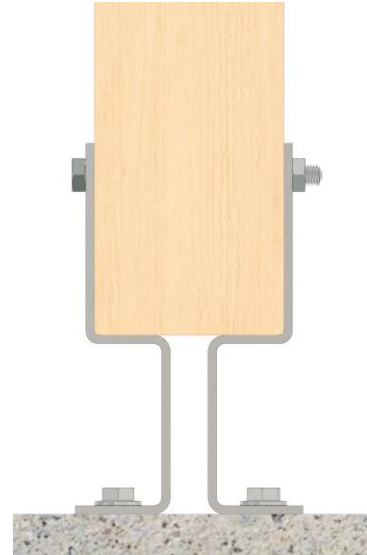

BOLT LENGTH

- When using hex head bolts for fastening your post, it is recommended to use a length 20mm longer than post side or have a minimum of 2x thread pitch extend beyond the outward surface of the hex nut.
- Account for the thickness of the saddle, washer(s) and allow sufficient thread of the bolt to pass the hex nut.
- For example, a 110mm hex head bolt would suit a 90mm post anchor as shown for Half-Stirrup, Full-Stirrup and Centre-Fix.

POST FASTENERS

- Buildex offer a 40 & 50mm Construction Screw designed specifically for fixing Post Anchors.
- The enlarged shank is designed for M10 holes, and the self-drilling point requires no pre-drilling.
- Product Information:
18G x 40mm, 20 pack – X998278
18G x 50mm, 20 pack – X998292



CONCRETE FASTENERS

- For fixing to existing concrete, Pryda recommends the use of M10 Hex Head Ramset™ AnkaScrews™. Having 75mm minimum length or greater.
- Alternatively, Ramset M10 Galvanised Dynabolts can also be considered provided the connection is deemed “fit for purpose” by the project consulting Engineer.
- For detailed instructions on installation and design properties, see the Ramset website www.ramset.com.au

Contact Details	
Manufacture location	Overseas
Legal and trading name of manufacturer	Shanghai Zenith International Trading Company Co LTD
Legal and trading name of importer	Pryda New Zealand - a Division of ITW New Zealand
Importer address for service	23-29 Poland Road, Wairau Valley, Auckland, 0627, New Zealand
Importer website	pryda.co.nz
Importer email	info@prydaanz.com
Importer phone number	0800 88 22 44
Importer NZBN	9429039833129